

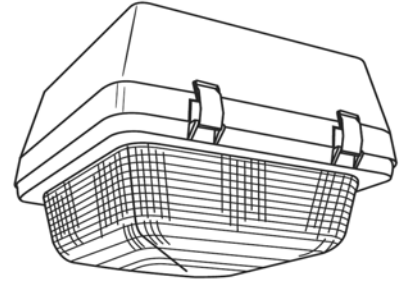

## ASM-19 CEILING MOUNT

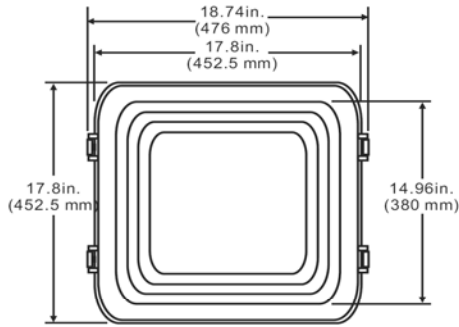
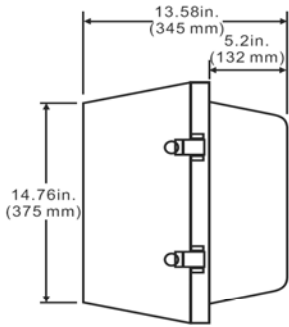

### PRODUCT FEATURES

- \* UL LISTED FOR WET LOCATIONS
  - \* HEAVY DUTY DIE-CAST ALUMINUM HOUSING WITH HIGH IMPACT / HEAT RESISTANT BOROSILICATE GLASS FOR ULTIMATE LIGHT DISTRIBUTION
  - \* DARK BRONZE COLOR
  - \* POWDER COATED FINISH ON THE HOUSING
  - \* SILICONE RUBBER INCLUDED TO PREVENT LEAKAGE
  - \* 1/2" TAPPED HOLES AVAILABLE FOR INSTALLING PHOTOCELL (PHOTOCELL OPTIONAL)
  - \* ONE PIECE ANODIZED ALUMINUM DESIGNED REFLECTOR FOR BEST LIGHT EFFICIENCY
- \* IDEAL FOR 400MH WATTS, 400HPS WATTS MAX



IDEAL FOR PARKING AREAS, ENTRANCES, WALKWAYS, UNDERPASSES, LOADING DOCKS, RECREATION AREAS. AND GAS STATION.

CATALOG #	RATING	LAMPS	DIMENSIONS
ASM19-MH	400W MAX MT( SPECIFY WATTAGE)	METAL HALIDE	18.74" W X 17.8" H X 13.58" D
ASM19-HPS	400W MAX MT( SPECIFY WATTAGE)	H.P.S	18.74" W X 17.8" H X 13.58" D



1435 West 139TH Street Gardena, CA 90249 Tel: 310-323-2275 Fax: 310-323-6275

Website: [www.arklighting.com](http://www.arklighting.com) Email: [info@arklighting.com](mailto:info@arklighting.com)